

3CX MAX. ENGINE POWER: 63kW (85hp) or 68.6kW (92hp) MAX. BACKHOE DIG DEPTH: 4.75 metres (15ft 7in) MAX. LOADER CAPACITY: 1.0m<sup>3</sup> (1.32yd<sup>3</sup>)

3CX SITEMASTER MAX. ENGINE POWER: 63kW (85hp) or 68.6kW (92hp) MAX. BACKHOE DIG DEPTH: 5.97 metres (19ft 7in) MAX. LOADER CAPACITY: 1.0m<sup>3</sup> (1.32yd<sup>3</sup>)

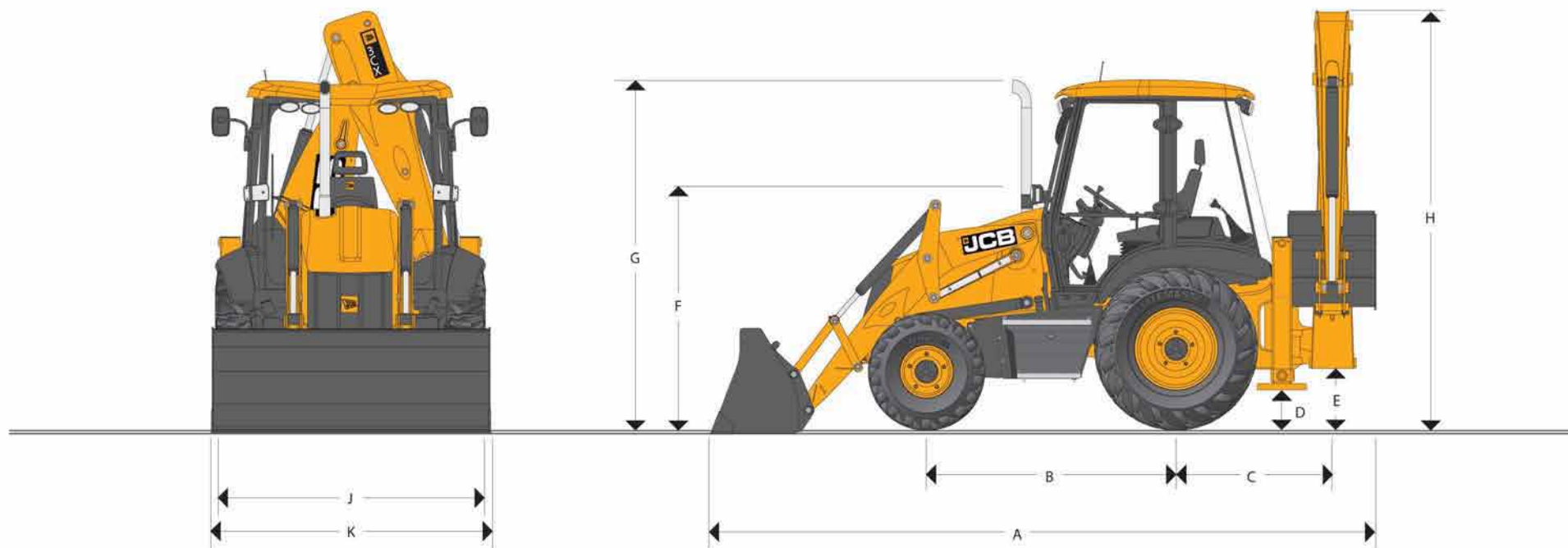

### STATIC DIMENSIONS

JCB Backhoe Loaders feature heavy duty one piece mainframe, componentised driveline and fully enclosed engine compartment. All fluid and component compartments are lockable using the ignition key.

Machine model	3CX m (ft-in)	3CX Sitemaster m (ft-in)
A Total travel length	5.62 (18-5)	5.62 (18-5)
B Axle centreline distance	2.17 (7-1)	2.17 (7-1)
C Slew centre to rear axle centre distance	1.36 (4-6)	1.36 (4-6)
D Stabiliser feet clearance	0.37 (1-2)	0.37 (1-2)
E Kingpost clearance	0.52 (1-8)	0.52 (1-8)
F Steering wheel centre height	1.94 (6-4)	1.94 (6-4)
G Cab roof height	2.87 (9-5)	2.87 (9-5)

Machine model	3CX m (ft-in)		3CX Sitemaster m (ft-in)	
H Total travel clearance	3.61 (11-10)		3.61 (11-10)	
J Rear frame width	2.35 (7-8)	2.24 (7-4)*	2.35 (7-8)	2.24 (7-4)*
K Shovel width	2.35 (7-8)	2.23 (7-4)*	2.35 (7-8)	2.23 (7-4)*

\* Narrow option

## BACKHOE DIMENSIONS

Model		3CX	
		3CX	3CX Sitemaster 3CX Contractor
		Standard Dipper m (ft-in)	Extradig m (ft-in)
A SAE max dig depth	Ext	-	5.46 (17-11)
	Ret	4.24 (13-11)	4.24 (13-11)
SAE 2ft flat bottom	Ext	-	5.43 (17-10)
	Ret	4.21 (13-10)	4.21 (13-10)
Maximum dig depth with deep profile bucket	Ext	-	5.97 (19-7)
	Ret	4.75 (15-7)	4.75 (15-7)
B Reach – ground level to rear wheel centre	Ext	-	7.87 (25-10)
	Ret	6.72 (22-1)	6.72 (22-1)
C Reach – ground level to slew centre	Ext	-	6.52 (21-5)
	Ret	5.37 (17-7)	5.37 (17-7)
D Reach – at full height to slew centre	Ext	-	3.66 (12-0)
	Ret	2.74 (9-0)	2.74 (9-0)
E Side reach – to centre line of machine	Ext	-	7.09 (23-3)
	Ret	5.94 (19-6)	5.94 (19-6)
F SAE operating height	Ext	-	6.35 (20-10)
	Ret	5.53 (18-2)	5.53 (18-2)
G Maximum loadover height	Ext	-	4.72 (15-6)
	Ret	3.84 (12-7)	3.84 (12-7)
SAE loadover height	Ext	-	4.32 (14-2)
	Ret	3.4 (11-3)	3.4 (11-3)
H Total kingpost travel		1.16 (3-10)	1.16 (3-10)
	Narrow rear frame option	1.05 (3-5)	1.05 (3-5)
J Bucket rotation	Speed	201°	201°



## BACKHOE PERFORMANCE – 3CX Contractor

		kgf (lbf)
Bucket tearout	Speed	5385 (11847)
	Power	6228 (13701)
Dipper tearout – standard lift excavator	Ext	2255 (4961)
	Ret	3225 (7095)
Dipper tearout – heavy lift excavator	Ext	2729 (6004)
	Ret	3903 (8587)
Lift capacity of bucket pivot at	Ext	719 (1582)
Full reach – standard lift excavator	Ret	1451 (3192)
		kg (lb)
Lift capacity of bucket pivot at full reach – heavy lift excavator	Ext	1082 (2380)
	Ret	1885 (4147)

## BACKHOE PERFORMANCE – 3CX, 3CX Sitemaster, 3CX Super, 3CX Super Sitemaster

		Standard Dipper	Extradig
		kgf (lbf)	kgf (lbf)
Bucket tearout	Speed	5431 (11948)	5385 (11847)
	Power	6324 (13912)	6228 (13701)
Dipper tearout	Ext	-	2255 (4961)
	Ret	3217 (7077)	3225 (7095)
		kg (lb)	kg (lb)
Lift capacity of bucket pivot at full reach	Ext	-	719 (1582)
	Ret	1584 (3485)	1451 (3192)

## BACKHOE DIMENSIONS

Model		3CX Super	3CX Super & 3CX Super Sitemaster
		Standard dipper	Extradig
		m (ft-in)	m (ft-in)
A SAE max dig depth	Ext.	–	5.58 (18-4)
	Ret.	4.37 (14-4)	4.37 (14-4)
SAE 2ft flat bottom	Ext.	–	5.55 (18-3)
	Ret.	4.34 (14-3)	4.34 (14-3)
Maximum dig depth with deep profile bucket	Ext.	–	5.93 (19-5)
	Ret.	4.72 (15-6)	4.72 (15-6)
B Reach – ground level to rear wheel centre	Ext.	–	7.88 (25-10)
	Ret.	6.74 (22-1)	6.74 (22-1)
C Reach – ground level to slew centre	Ext.	–	6.54 (21-5)
	Ret.	5.40 (17-9)	5.40 (17-9)
D Reach – at full height to slew centre	Ext.	–	3.75 (12-4)
	Ret.	2.82 (9-3)	2.82 (9-3)
E Side reach – to centre line of machine	Ext.	–	7.09 (23-3)
	Ret.	5.94 (19-6)	5.94 (19-6)
F SAE operating height	Ext.	–	6.20 (20-4)
	Ret.	5.39 (17-8)	5.39 (17-8)
G Maximum loadover height	Ext.	–	4.67 (15-4)
	Ret.	3.78 (12-5)	3.78 (12-5)
SAE loadover height	Ext.	–	4.22 (13-10)
	Ret.	3.33 (10-11)	3.33 (10-11)
H Total kingpost travel		1.05 (3-5)	1.05 (3-5)
J Bucket rotation	Speed	201°	201°

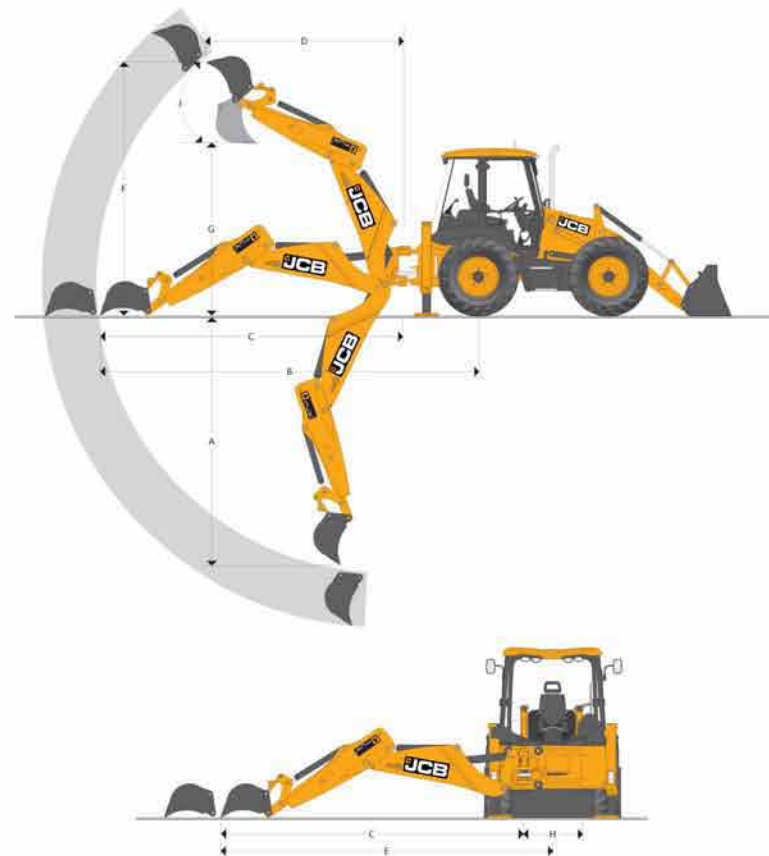



MAX. ENGINE POWER: 74.2kW (100hp)    MAX. BACKHOE DIG DEPTH: 5.97 metres (19ft 7in)    MAX. LOADER CAPACITY: 1.0m<sup>3</sup> (1.32yd<sup>3</sup>)

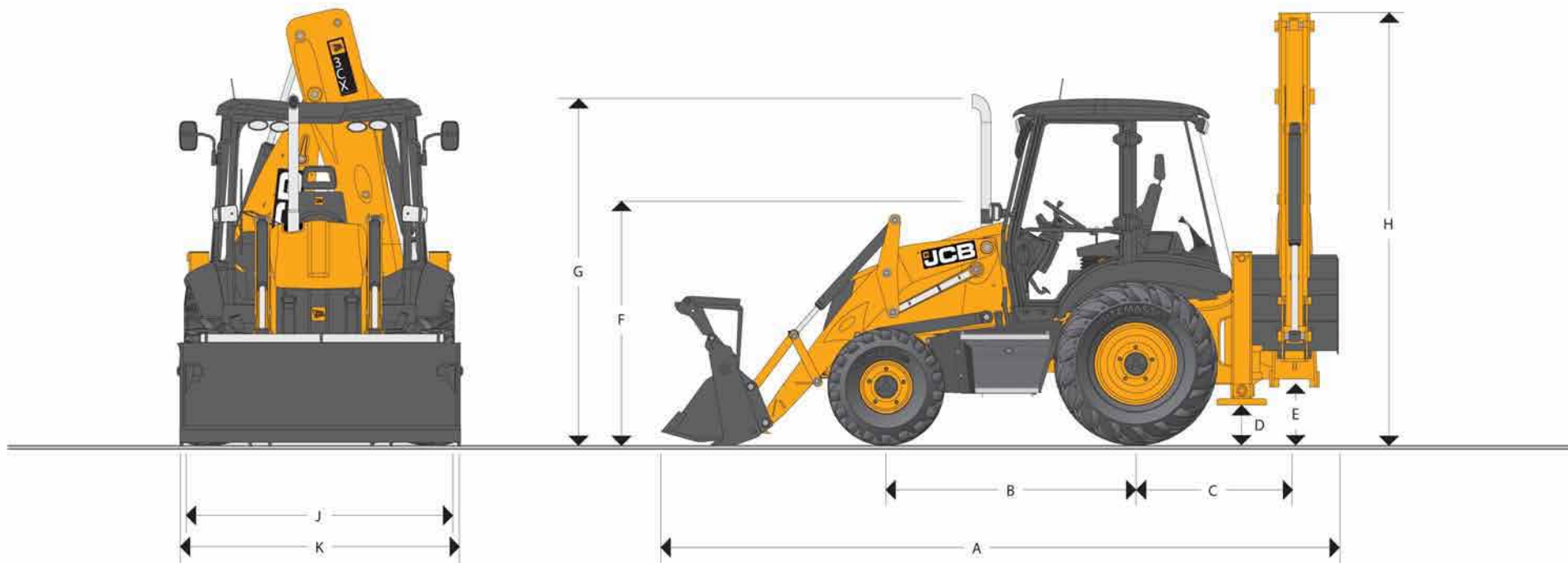

### STATIC DIMENSIONS

JCB Backhoe Loaders feature heavy duty one piece mainframe, componentised driveline and fully enclosed engine compartment. All fluid and component compartments are lockable using the ignition key.

Machine model	3CX Contractor
	m (ft-in)
A Total travel length	5.62 (18-5)
B Axle centreline distance	2.17 (7-1)
C Slew centre to rear axle centre distance	1.36 (4-6)
D Stabiliser feet clearance	0.37 (1-2)
E Kingpost clearance	0.52 (1-8)
F Steering wheel centre height	1.94 (6-4)
G Cab roof height	2.91 (9-6)

Machine model	3CX Contractor	
	m (ft-in)	
H Total travel clearance	3.61 (11-10)	
J Rear frame width	2.35 (7-8)	2.24 (7-4)*
K Shovel width	2.35 (7-8)	2.23 (7-4)*

\* Narrow option



3CX SUPER MAX. ENGINE POWER: 68.6kW (92hp) MAX. BACKHOE DIG DEPTH: 4.72 metres (15ft 6in) MAX. LOADER CAPACITY: 1.0m<sup>3</sup> (1.32yd<sup>3</sup>)

3CX SUPER SITEMASTER MAX. ENGINE POWER: 68.6kW (92hp) MAX. BACKHOE DIG DEPTH: 5.93 metres (19ft 5in) MAX. LOADER CAPACITY: 1.0m<sup>3</sup> (1.32yd<sup>3</sup>)

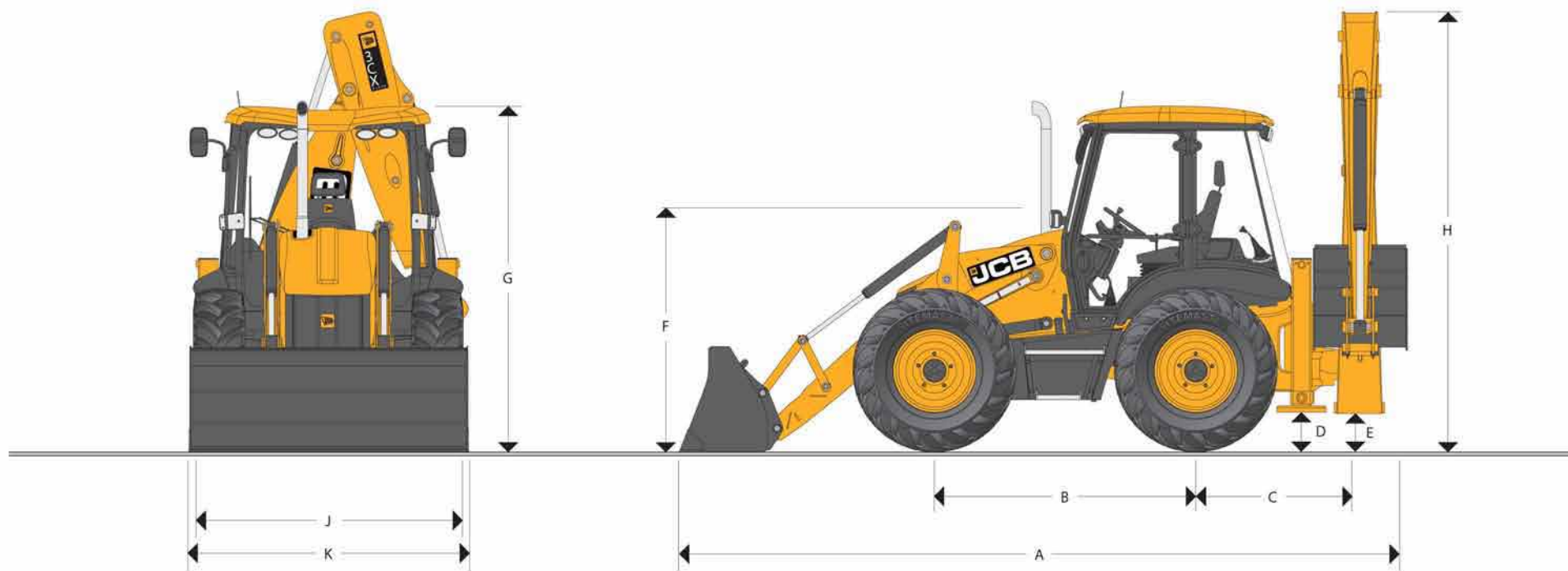

### STATIC DIMENSIONS

JCB Backhoe Loaders feature heavy duty one piece mainframe, componentised driveline and fully enclosed engine compartment. All fluid and component compartments are lockable using the ignition key.

Machine model	3CX Super m (ft-in)	3CX Super Sitemaster m (ft-in)
A Total travel length	5.91 (19-5)	5.91 (19-5)
B Axle centreline distance	2.22 (7-3)	2.22 (7-3)
C Slew centre to rear axle centre distance	1.36 (4-6)	1.36 (4-6)
D Stabiliser feet clearance	0.33 (1-1)	0.33 (1-1)
E Kingpost clearance	0.48 (1-7)	0.48 (1-7)

Machine model	3CX Super m (ft-in)	3CX Super Sitemaster m (ft-in)
F Steering wheel centre height	1.86 (6-1)	1.86 (6-1)
G Cab roof height	2.86 (9-4)	2.86 (9-4)
H Total travel clearance	3.48 (11-5)	3.56 (11-10)
J Rear frame width	2.24 (7-4)	2.24 (7-4)
K Shovel width	2.23 (7-4)	2.23 (7-4)

**GROUND LINE ANGLES**

3CX Super, 3CX Super Sitemaster

- A Approach angle 74°
- B Interference angle/ramp to ground plane 118°
- C Departure angle 19°



3CX, 3CX Contractor, 3CX Sitemaster

- A Approach angle 66°
- B Interference angle/ramp to ground plane 120°
- C Departure angle 20°

**OPERATING WEIGHTS**

Operating weight includes machine equipped with cab, 610mm excavator bucket and full fuel tank.

Machine model	3CX	3CX Sitemaster	3CX Contractor	3CX Super	3CX Super Sitemaster
	kg (lb)	kg (lb)	kg (lb)	kg (lb)	kg (lb)
Standard dipper and GP shovel	7370 (16250)	-	-	7725 (17000)	-
Extradig with 6-in-1 shovel and forks	8070 (17800)	8070 (17800)	8070 (17800)	8425 (18550)	8425 (18550)

**STEERING**

Full power hydrostatic system utilising the main hydraulic pump via a steering priority valve. In the event of engine failure, emergency steering is maintained.

Machine model	3CX, 3CX Sitemaster, 3CX Contractor	3CX Super, 3CX Super Sitemaster
Axles	Steer drive	Steer drive
Steering turns – lock to lock	2¼	2¼
	m (ft-in)	m (ft-in)
Kerb – kerb turning circle – unbraked	8.1 (26-7)	9.35 (30-8)
Loader clearance circle – unbraked	10.4 (34-1)	11.15 (36-7)
Kerb – kerb turning circle – braked	6.9 (22-8)	8.0 (26-3)
Loader clearance circle – braked	9.5 (31-2)	9.5 (31-2)

(Depending on tyre size, ground conditions etc.)

**ENGINE SUPPORT SYSTEM**

Engine support system is designed for ease of daily checks, routine maintenance and longer service intervals.

Fuel type	Diesel.
Fuel filter	Replaceable cartridge plus water/sediment separator prefilter.
Air cleaner	Dual, dry element type with self cleaning internal air intake precleaner.
Oil filter and lubrication	Full flow, spin-on type filter.
Cooling system	Hot climate specification, pressurised 14.5 psi (1.0 bar) suction fan. Pressurised recovery tank with integral filler neck.

**ENGINE (Stage II Emissions)**

Direct injection diesel, belt driven water pump, cold start aid – territory dependent.

Machine models	3CX 3CX Sitemaster	3CX, 3CX Sitemaster, 3CX Super, 3CX Super Sitemaster	3CX Contractor
Manufacturer	JCB	JCB	JCB
Aspiration	Naturally aspirated	Turbocharged	Turbocharged
Displacement	4.4 Ltr	4.4 Ltr	4.4 Ltr
No. of cylinders	4	4	4
Bore	mm 103	103	103
Stroke	mm 132	132	132
Rated engine RPM	2200	2200	2200
Power ratings			
Rated ISO 14396 (SAE J1995 Gross) kW (HP)	63 (85)	68.6 (92)	74.2 (100)
Maximum torque			
Rated ISO 14396 (SAE J1995 Gross) N m (lbf ft)	320 (236)	400 (295)	425 (313.5)
Max. torque RPM	1200	1200	1300

**ENGINE (Stage III Emissions)**

Direct injection diesel, belt driven water pump, cold start aid – territory dependent.

Machine models	3CX 3CX Sitemaster	3CX, 3CX Sitemaster, 3CX Super, 3CX Super Sitemaster	3CX Contractor
Manufacturer	JCB	JCB	JCB
Aspiration	Turbocharged	Turbocharged	Turbocharged & Intercooled
Displacement	4.4 Ltr	4.4 Ltr	4.4 Ltr
No. of cylinders	4	4	4
Bore	mm 103	103	103
Stroke	mm 132	132	132
Rated engine RPM	2200	2200	2200
Power ratings			
Rated ISO 14396 (SAE J1995 Gross) kW (HP)	63 (85)	68.6 (92)	74.2 (100)
Maximum torque			
Rated ISO 14396 (SAE J1995 Gross) N m (lbf ft)	362 (267)	408 (301)	440 (324.5)
Max. torque RPM	1200	1200	1300



## ELECTRICAL AND INSTRUMENTATION

12 volt negative ground, utilising wiring and connectors meeting IP69 water ingress test standard. Central fuse panel.	
Gauges	Tachometer, engine coolant temp, fuel level, hourmeter, clock.
Warning system	Audible and visual system for engine oil, water in fuel, transmission oil temperature and pressure, park brake, air cleaner, alternator.
Battery	900 CCA/110 A/hr.
Pre-wire	Radio speakers (cab), beacon (all).
Horn	Controlled from both front and rear.
Alternator	95 amp standard.
Front working lights	4 adjustable.
Rear working lights	4 adjustable.

## JCB TORQUE LOCK (Optional)

An industry exclusive, JCB Torque Lock enables an operator to dramatically reduce travel time and improve fuel efficiency during roading operations.

Torque Lock incorporates a clutch which, when engaged, enables a direct connection between the engine and gearbox. By "locking up" the torque converter slippage is eliminated. Torque Lock engages automatically in 4th gear (Powershift models) or "A" mode (Autoshift models).

Torque Lock reduces fuel consumption by up to 25%, maintains road speed up hills for longer and allows the machine to reach its destination quicker or increase its working radius.

Not available on Synchroshuttle models.

## REAR AXLE

JCB rear axles are designed and built specifically for backhoe loaders and accept a wide variety of tyre combinations.

Machine model	3CX, 3CX Contractor, 3CX Sitemaster	3CX Super, 3CX Super Sitemaster
Type	JCB epicyclic hub reduction with torque proportional	JCB 4WD steer drive with torque proportional
Limited Slip	Option	Option
Axle ratings	kg (lb)	kg (lb)
Static load rating	25000 (55116)	25000 (55116)
Dynamic load rating	12500 (27558)	12500 (27558)
Steering ram	Powered track rod	Powered track rod

## FRONT AXLE

JCB front axles are designed and built specifically for backhoe loaders and accept a wide variety of tyre combinations.

Machine model	3CX 2WD	3CX 4WD, 3CX Contractor, 3CX Sitemaster	3CX Super, 3CX Super Sitemaster
Type	Flame cut bar	JCB steer drive with torque proportional	JCB 4WD steer drive with torque proportional
Axle ratings	kg (lb)	kg (lb)	kg (lb)
Static load rating	16500 (36376)	16500 (36376)	25000 (55116)
Dynamic load rating	8300 (18298)	8300 (18298)	12500 (27558)
Oscillation angle	16°	16°	16°
Steering ram	Powered track rod	Powered track rod	Powered track rod

## TRANSMISSION

The JCB Transmissions are designed and built specifically for JCB Backhoe Loaders. They feature synchronised shifting in all gears. Powershuttle between forward and reverse. Ground speeds are designed to maximise productivity.

An optional 4 speed powershift transmission enables effortless and fast gear changes. Gears are selected through a twist grip control on the column mounted forward/reverse lever.

Machine model	3CX Super, 3CX Super Sitemaster		3CX, 3CX Sitemaster, 3CX Contractor		3CX Contractor
Manufacturer	JCB	JCB	JCB	JCB	JCB
Type	Synchroshuttle	Powershift	Synchroshuttle	Powershift	Auto Powershift
Torque converter	305mm (12")	305mm (12")	305mm (12")	305mm (12")	305mm (12")
Torque converter ratio	2.54:1	2.54:1	2.54:1	2.54:1	2.54:1
Torque Lock	N/A	Option	N/A	Option	Option
Gears forward/reverse	4/4	4/4	4/4	6/4	
Gear selection	Manual	Powershift	Manual	Powershift	Powershift
Shuttle control – F/R	Power shuttle	Power shuttle	Power shuttle	Power shuttle	Power shuttle
Travel speeds	kph (mph)	kph (mph)	kph (mph)	kph (mph)	kph (mph)
Tyres equipped	16.9x24 Goodyear Sure Grip		F: 12.5x18 R: 18.4x26 T219 JCB SM		F: 12.5x18 R: 18.4x26 T219 JCB SM
Gear 1	5.7 (3.5)	4.9 (3.0)	6.2 (3.9)	5.4 (3.4)	5.1 (3.2) F/6.8 (4.2) R
Gear 2	9.1 (5.7)	8.6 (5.3)	10.0 (6.2)	10.0 (6.2)	8.6 (5.3) F/8.4 (5.3) R
Gear 3	19.6 (12.2)	19.8 (12.3)	21.3 (13.2)	22.5 (14.0)	11.6 (7.2) F/22.8 (14.2) R
Gear 4	37.1 (23.1)	37.1 (23.1)	39.8 (24.7)	38.3 (23.8)	18.7 (11.6) F/29.5 (18.3) R
Gear 5	-	-	-	-	31.1 (19.3) F/-
Gear 6	-	-	-	-	38.3 (23.8) F/-

## CAB

Excellent visibility (and safety) is provided by the extra large tinted glass areas of 6.4 sq m (70 sq ft). Cab frame is ROPS and FOPS approved for maximum operator protection. ISO standard 3471 and 3449 (SAE J1040 and J231).

- A fully adjustable seat with lumbar support combines with ergonomically positioned controls to minimise operator fatigue.
- The in-cab noise levels are the lowest in the business for maximum operator comfort.
- A radio location is provided as standard plus twin speakers for stereo sound.
- Cab provides easy access through a two door frame. Rear side windows open either partially or fully for extra ventilation. Standard features include: lap seat belt, 3 speed fresh air/recycle heater, front and rear screen wash/wipers, front and rear horn, exterior mirrors, and flat easy-clean floor.
- The instrument panel is positioned to the right-hand side for ease of viewing from either the loading or excavating position and has an optional lockable cover for vandal proofing. Engine speed, fuel and coolant temperature gauges, (and clock on cab builds) are mounted in the panel.
- A high performance air conditioning system is optionally available providing the operator with a cool working environment when working in high temperatures.
- Mechanical suspension seat gives the operator a comfortable operating position.
- An optionally available heated air suspension seat gives the operator the ultimate comfort with automatic compensation for weight.

## EASYCONTROL (Optional)

JCB EasyControl offers smooth, low effort and productive backhoe operation, while reducing operator fatigue. Excavator control joysticks are integrated into the seat, providing increased legroom, improved visibility and hydraulic excavator ergonomics. A proportional switch is mounted in the joystick to operate JCB's Extradig and optional auxiliary circuits are also available to operate various attachments. The low effort mechanical loader control incorporates a proportional switch to operate loader mounted attachments. Best in class hydraulic modulation combined with the greatest digging performance, means that the JCB EasyControl is unmatched in any backhoe loader. This option is available on 92hp and 100hp open centre systems only.

## ADVANCED EASYCONTROL (Optional)

Advanced EasyControl is an alternative hydraulic control system available on select JCB 3CX and 4CX backhoe loaders. Building on the successful EasyControl system, it offers even higher levels of operator comfort, control and performance. Features include: seat mounted controls which operate both the excavator and loader; plus a telescopic steering column with integrated forward and reverse control for greater comfort. In addition, Advanced EasyControl boasts high output variable flow hydraulics which provides full flow on demand for increased fuel efficiency, faster digging cycles and maximum productivity and additional filtration for improved efficiency and reliability.

## POWER BRAKES

The JCB class leading hydraulic power brakes system is fitted as standard and ensures low effort, effective, fade-free braking. The self-adjusting, multi-disc arrangement is inboard mounted and is oil immersed for minimum maintenance and a long operating life.

- A 3 position switch allows the selection of 2 wheel drive with two wheel braking; 2 wheel drive with four wheel braking or 4 wheel drive with four wheel braking.
- Twin brake pedals provide tighter turning circle and enhanced steering control on slippery ground.
- Automatic compensation ensures 'straight' machine braking.
- Accumulator back-up provides maximum safety under all conditions and in the case of dead engine applies 4 wheel braking.
- Transmission logic and spring on / hydraulic release 4WD clutch means that the park brake is always applied to front and rear axles for effective braking.
- Increased back off in the brake packs reduces friction and saves fuel.
- Uses the main hydraulic system oil which eliminates the need for a separate brake oil reservoir which also reduces service costs.
- Class leading brakes have proportional braking effort throughout the pedal travel.
- Disc diameter: 220 mm (8.7 in). Friction area: 129,000 sq.mm (200 sq. in) per brake.
- For synchromesh transmissions, the independent parking brake is mounted on the input shaft of the rear axle and will hold the machine on 1:3 gradients. It is an over-centre type, adjustable within the cab, with transmission disconnect to prevent premature brake pad wear. Park brake disc diameter: 280mm (11 in). Friction area 5416 sq. mm (8.4 sq.in).
- For powershift transmissions, the integral park brake is a ball and ramp, oil immersed type located within the transmission and will hold the machine on 1:3 gradients. It is an over-centre type, adjustable within the cab, with transmission disconnect to prevent premature brake pad wear. There are 5 friction brake discs having an outside diameter of 127mm (5 in). Frictional area per brake disc is 47.65 sq. cm (7.39 sq. in) giving a total frictional area of 476.5 sq. cm (73.9 sq. in).

## TYRES

	3CX, Sitemaster	Contractor	Super, Super Sitemaster
Front	12.5 x 18 x 10 Traction or Industrial	16 x 20, 10PR Traction or Industrial	14.9/14 x 24, 12PR Industrial
	400/70 R18 Traction or Industrial	400/70 R20 Traction or Industrial	16.9/14 x 24, 12PR Industrial
Rear	340/80 R18 Traction	12.5 x 20 x 10 Industrial	460/70 x 24, Radial Traction
	16.9 x 28, 12PR Traction or Industrial	18.4 x 26, 12PR Traction or Industrial	14.9/14 x 24, 12PR Industrial
	18.4 x 26, 12PR Traction or Industrial	19.5L – R28 Traction	16.9/14 x 24, 12PR Industrial
	440/80 R28, Traction	500/70 R28 Traction	460/70 x 24, Radial Traction
	480/80 x R26, Radial Industrial	18.4 x 30 x 14 Industrial	



### JCB SMOOTH RIDE SYSTEM (Optional)

The JCB Smooth Ride System (SRS) consists of a dry nitrogen and oil filled accumulator installed in line with the loader lift cylinders. When activated, the Smooth Ride System allows the loader arms to float. This action counteracts variations in road or site surfaces and provides the operator with a smooth ride. The JCB Smooth Ride System is manually controlled, via a rocker switch on the instrument panel, for maximum benefit and user flexibility.

### JCB POWERSLIDE (Optional)

Exclusive to JCB, this factory fit option enables the excavator's sideshift carriage to be hydraulically powered across the rearframe by the operation of a pedal or joystick mounted proportional switch (EasyControl) in the cab. With this feature there is no need to "push" the carriage across with the bucket avoiding ground damage and the need to relocate the whole machine.

### SERVICE CAPACITIES

Machine model	All models
	ltr (gal)
Cooling system	18.5 (4.1)
Fuel tank	160 (35.2)
Engine oil with filter	15 (3.3)
Gearbox with filter	16 (3.5)
Rear axle	16 (3.5)
Front drive axle	16 (3.5)
Hydraulic system incl. tank	132 (29)

### AUXILIARY CIRCUITS

The JCB hydraulic hand-held tool circuit, an industry exclusive, can run a variety of tools including breakers, pumps, and disc cutters, eliminates the need for separate power packs.

Meets the EHTMA Class C tools operation:  
Pressure 138 bar  
Maximum flow 20 lpm

The JCB Hammer circuit has the ability to switch between low-flow and high-flow circuits to operate single flow attachments such as hammers, patch planers and compactors.

A combined hammer and bi-directional circuit is also available with the ability to switch between low-flow and high-flow circuits to operate the full range of attachments for incredible versatility.

### HYDRAULIC SYSTEM

The Open Centre system uses three gear pumps and Hydraulic Speed Control (HSC) with a power modulation valve that automatically varies hydraulic power to match digging conditions for extra performance, control and power.

- In the EcoDig mode the innovative three pump design allows excavating at lower RPM to reduce fuel consumption and engine emissions by up to 15%, without reducing performance. (Manual and EasyControl machines only).
- A Power Modulation Valve automatically varies the hydraulic power to match digging conditions to improve performance and efficiency – automatically dumps one pump when 4th gear selected on powershift models.
- The HSC switch enables controlled use of hydraulic response depending upon application.
- An independent pump powers the Extradig dipper so that it can extend or retract without breaking the digging cycle. This allows faster cycle times and simultaneous use of the telescopic and normal excavator actions in operations such as grading and bank dressing.

The alternative Closed Centre system uses a single variable flow axial piston pump. This load sensing system matches flow to work demand improving productivity and efficiency. Both systems incorporate:

- Ergonomically positioned levers allowing excellent control of the loader and backhoe.
- A full flow 10 micron filter ensures that oil stays free of contaminants.

Pump flows at 2200rpm*	3CX, 3CX Sitemaster	3CX, 3CX Super, 3CX Sitemaster, 3CX Super Sitemaster, 3CX Contractor	3CX Contractor**
Open centre systems (Gear pumps)	l/min (gal/min)	l/min (gal/min)	l/min (gal/min)
Manual Control (Gear pump)			
Manual main pump	73 (16)	80 (17.6)	81 (17.8)
Manual second pump	51 (11.2)	64 (14.1)	73 (16)
EasyControl			
Manual main pump	–	80 (17.6)	81 (17.8)
Manual second pump	–	64 (14.1)	73 (16)
Closed centre systems (Piston pump)	l/min (gal/min)	l/min (gal/min)	l/min (gal/min)
Advanced EasyControl	–	165 (32.3)	165 (32.3)
	bar (lbf/sq in)	bar (lbf/sq in)	bar (lbf/sq in)
System relief pressure	251 (3650)	251 (3650)	251 (3650)

\*Optimum flow \*\*Territory specific

**LOADER DIMENSIONS – 3CX, 3CX Contractor, 3CX Sitemaster**

**LOADER DIMENSIONS – 3CX, 3CX Contractor, 3CX Sitemaster**

	GP shovel m (ft-in)	6-in-1 shovel m (ft-in)
M Dump height	2.74 (9-0)	2.72 (8-11)
N Load over height	3.23 (10-7)	3.20 (10-6)
O Loader hinge pin height	3.45 (11-4)	3.45 (11-4)
P Pin forward reach	0.36 (1-2)	0.36 (1-2)
Q Reach at ground (toe plate horizontal)	1.42 (4-8)	1.37 (4-6)
R Max. reach at full height	1.20 (3-11)	1.15 (3-9)
S Reach at full height fully dumped	0.83 (2-9)	0.78 (2-7)
T Dig depth	0.07 (0-3)	0.10 (0-4)
U Roll back at ground	45°	45°
V Dump angle	43°	43°
Jaw opening width	–	0.95 (3-1)

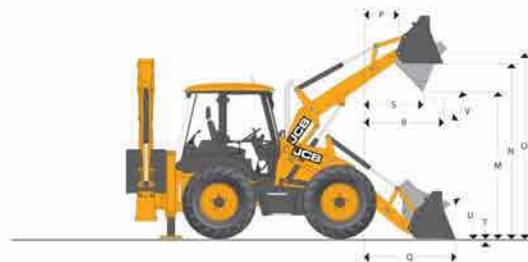
**LOADER DIMENSIONS – 3CX Super, 3CX Super Sitemaster**

**LOADER DIMENSIONS – 3CX Super, 3CX Super Sitemaster**

	G.P shovel m (ft-in)	6-in-1 shovel m (ft-in)
M Dump height	2.64 (8-8)	2.64 (8-8)
N Load over height	3.16 (10-4)	3.13 (10-3)
O Pin height	3.41 (11-2)	3.41 (11-2)
P Pin forward reach	0.47 (1-6)	0.47 (1-6)
Q Reach at ground (toe plate horizontal)	1.52 (5-0)	1.50 (4-11)
R Max. reach at full height	1.26 (4-2)	1.22 (4-0)
S Reach at full height fully dumped	0.88 (2-10)	0.82 (2-8)
T Dig depth	0.18 (0-7)	0.23 (0-9)
U Rollback at ground	45°	45°
V Dump angle	44°	44°
Jaw opening width	–	0.95 (3-1)

**LOADER DIMENSIONS – Forklift Performance Data – 3CX, 3CX Contractor, 3CX Sitemaster**

	6-in-1 shovel mounted forks m (ft-in)	Quickhitch mounted forks m (ft-in)
W Forks – tine length	1.1 (3-7)	1.1 (3-7)
Forks – tine width	0.08 (0-3.1)	0.08 (0-3.1)
X Forks reach at ground level	2.66 (8-9)	2.03 (6-8)
Y Forks reach at full height	2.25 (7-5)	1.72 (5-8)
Z Forks lift height – max.	2.92 (9-7)	3.27 (10-9)
Fork spacing – min	0.2 (0-8)	0.2 (0-8)
Fork spacing – max	2.17 (7-3)	1.03 (3-4)
SWL @ 500mm load centres	kg (lb)	1000 (2205)
		2000 (4410)

**LOADER ATTACHMENTS – Direct Mount – All models**

Loader buckets are listed according to size and application. All buckets are drilled to accept optional auxiliary cutting edge or teeth. Flat top box section provides rigidity and assists in bucket levelling.

Width mm (ft-in)	Capacity SAE	
	Rated m <sup>3</sup> (yd <sup>3</sup> )	Struck m <sup>3</sup> (yd <sup>3</sup> )
	G.P shovel	
2235 (7-4)	1.0 (1.32)	0.83 (1.09)
2350 (7-8)	1.1 (1.44)	0.91 (1.19)
	6-in-1 shovel	
2235 (7-4)	1.0 (1.32)	0.76 (1.00)
2350 (7-8)	1.0 (1.32)	0.76 (1.00)

## LOADER ATTACHMENTS



## LOADER ATTACHMENTS – Forklift Performance and Data – 3CX Super, 3CX Super Sitemaster

	6-in-1 Shovel mounted forks		Quickhitch mounted forks	
	m (ft-in)		m (ft-in)	
W Fork length	1.1 (3-7)		1.1 (3-7)	
Section width	0.08 (0-3/8)		0.08 (0-3/8)	
X Reach at ground	2.78 (9-1)		2.18 (7-2)	
Y Reach at full height	2.38 (7-10)		1.81 (5-11)	
Z Fork lift height	2.85 (9-4)		3.23 (10-7)	
Fork spacing – min	0.2 (0-8)		0.2 (0-8)	
Fork spacing – max	2.17 (7-3)		1.03 (3-4)	
SWL @ 500mm load centres	kg (lb)	1000 (2205)	2000 (4410)	

Integrated Quickhitch and Forks are unique to JCB and speeds up attachment changeover times and increases productivity. Mechanical or hydraulic Quickhitch versions are available and with the shovel removed, the flip over forks maximise fork lift capacity to 2000kg and increases visibility to the load.

## LOADER PERFORMANCE

	3CX		3CX Super, 3CX Super Sitemaster	
	kgf (lbf)		kgf (lbf)	
Shovel type	GP shovel	6 in 1	6 in 1	
Loader breakout – shovel	6170 (13603)	6531 (14398)	6590 (14498)	
Loader breakout – arms	4942 (10895)	4732 (10432)	5730 (12606)	
Max. lift capacity 7'4"	3479 (7670)	3229 (7119)	4378 (9631)	
Max. lift capacity 7'8"	3439 (7582)	3169 (6986)	–	
C lamping force	–	2940 (6480)	2945 (6479)	
	3CX Super	3CX Sitemaster, 3CX Contractor (Standard lift)	3CX Contractor (Heavy lift)	
Shovel type	GP shovel	6 in 1	6 in 1	
Loader breakout – shovel	6227 (13699)	6531 (14398)	6531 (14398)	
Loader breakout – arms	5936 (13059)	4732 (10432)	6203 (13675)	
Max. lift capacity 7'4"	4638 (10203)	3229 (7119)	4308 (9498)	
Max. lift capacity 7'8"	–	3169 (6986)	4248 (9365)	
C lamping force	–	2940 (6480)	2940 (6480)	

## BACKHOE ATTACHMENTS – Standard Profile Bucket

Width*	Capacity SAE		Weight (+ Teeth)	
	Rated m <sup>3</sup> (ft <sup>3</sup> )	Struck m <sup>3</sup> (ft <sup>3</sup> )	kg (lb)	Teeth
229 (9)	0.04 (1½)	0.03 (1)	95 (209)	0
305 (12)†	0.06 (2½)	0.05 (1¾)	102 (225)	3
356 (14)†	0.075 (2½)	0.06 (2)	105 (231)	3
400 (16)†	0.09 (3)	0.07 (2½)	109 (240)	3
457 (18)†	0.12 (4¼)	0.09 (3)	116 (256)	3
610 (24)†	0.17 (6)	0.13 (4½)	140 (310)	4
800 (32)†	0.24 (8½)	0.17 (6)	162 (355)	5
950 (37)†	0.30 (10½)	0.21 (7¼)	198 (435)	5

\* Including sidecutters. Width less sidecutters deduct 25mm (1in).

† Available with additional wear strips to give added strength and rigidity.

## DITCHING BUCKETS

Width*	Capacity SAE		Weight	
	Rated m <sup>3</sup> (ft <sup>3</sup> )	Struck m <sup>3</sup> (ft <sup>3</sup> )	kg (lb)	
1525 (60)	0.22 (7¾)	0.155 (5½)	150 (330)	
1830 (72)	0.26 (9)	0.186 (6½)	172 (379)	

## BACKHOE ATTACHMENTS – Deep Profile Bucket

Width*	Capacity SAE		Weight (+ Teeth)	
	Rated m <sup>3</sup> (ft <sup>3</sup> )	Struck m <sup>3</sup> (ft <sup>3</sup> )	kg (lb)	Teeth
305 (12)	0.09 (3)	0.07 (2½)	102 (225)	3
356 (14)	0.11 (4)	0.09 (3¾)	117 (257)	3
457 (18)	0.16 (5½)	0.13 (4½)	122 (269)	3
610 (24)	0.23 (8)	0.18 (6¼)	142 (314)	4
800 (32)	0.30 (10½)	0.24 (8½)	163 (359)	5
950 (37)	0.38 (½)†	0.30 (10½)	183 (403)	5
1100 (43)	0.48 (½)†	0.34 (12)	203 (448)	6

\* Including sidecutters. Width less sidecutters deduct 25mm (1in). † Capacity in cu.yd.

## TAPERED BUCKETS

Width*	Capacity SAE		Angle degrees	Teeth
	Rated m <sup>3</sup> (ft <sup>3</sup> )	Struck m <sup>3</sup> (ft <sup>3</sup> )		
381–1676 (15–66)	0.07 (2½)	0.06 (2)	30	2
305–1067 (12–42)	0.12 (4½)	0.10 (3½)	60	2