

## Weights

Operating weight (MARK)	8600 kg
Additional weight for steel tracks	30 kg
Additional weight for long dipperstick	57 kg
Ground pressure with rubber tracks	38.20 kPa

## Engine

Make / model	Yanmar / 4TNV98C-VDB8
Fuel	Diesel
Number of cylinders	4
Displacement	3319 cm <sup>3</sup>
Maximum net torque at 1360 RPM (SAE J1995)	241.0 Nm

## Performance

Digging force, dipperstick (ISO 6015)	43900 N
Digging force, long dipperstick (ISO 6015)	36600 N
Digging force, bucket (ISO 6015)	63000 N
Drawbar pull	66000 N
Travel speed, low range	2.7 km/h
Travel speed, high range	4.7 km/h

## Hydraulic System

Pump type	One engine-driven tandem axial piston pump and one engine-driven gear pump
Piston pump capacity	151.00 L/min
Auxiliary flow	95.00 L/min
System relief pressure for auxiliary circuits	250.00 bar
Auxiliary relief	210.0 bar
Relief pressure for implement circuit	295.0 bar

## Slew System

Boom swing, left	70°
Boom swing, right	55°
Slew rate	9.5 RPM

## Fluid Capacities

Cooling system	4.20 L
Engine lubrication plus oil filter	10.20 L
Fuel reservoir	110.00 L
Hydraulic system	148.00 L

## Environmental

Noise level LpA(EU Directive 2000/14/EC)	71 dB(A)
Noise level LWA(EU Directive 2000/14/EC)	98 dB(A)
Whole body vibration (ISO 2631-1)	0.32 ms <sup>-2</sup>
Hand-arm vibration (ISO 5349-1)	0.82 ms <sup>-2</sup>

## Standard Features

2300 mm dozer blade	Boom & arm safety valves
450 mm rubber tracks	Harness for rotating beacon
5.7 inch LCD screen	Fully adjustable air conditioning
Engine/hydraulic monitor with shutdown	Overload warning device
Fingertip auxiliary hydraulic control	Sun visor
Control console locks	Left rear view mirror
Hydraulic joystick controls	Electric refueling pump
Two-speed travel	Auto idle
Lockable storage compartment	Auto shift travel
Horn	Second auxiliary hydraulic line (Rotation piping)
Work lights	Auxiliary hydraulics (1st and 2nd circuits)
Retractable seat belt	Auxiliary lines on arm with quick couplers
Suspension seat with high back	Warranty: 12 months, 2000 hours (whichever occurs first)
Consoles with forwards/backwards adjustable displacement	

## Working Range

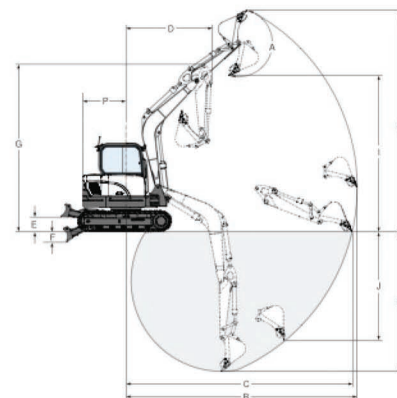

(A) 182°	(G) 5007.0 mm
(B) 6915.0 mm	(H) 6630.0 mm
(C) 6765.0 mm	(H*) 6980.0 mm
(C*) 7295.0 mm	(I) 4645.0 mm
(D) 2550.0 mm	(I*) 4995.0 mm
(D*) 2635.0 mm	(J) 3245.0 mm
(E) 437.0 mm	(K) 4175.0 mm
(F) 304.0 mm	(K*) 4725.0 mm

## Dimensions

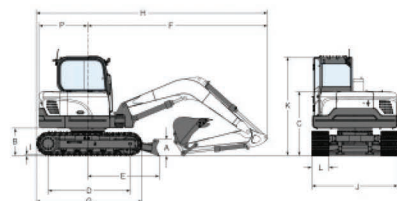

(A) 408.0 mm	(I) 26.0 mm
(B) 735.0 mm	(J) 2300.0 mm
(C) 1715.0 mm	(K) 2640.0 mm
(D) 2200.0 mm	(L) 450.0 mm
(E) 1910.0 mm	(M) 704.0 mm
(F) 4785.0 mm	(N) 837.0 mm
(G) 2825.0 mm	(O) 2550.0 mm
(H) 6165.0 mm	(P) 1300.0 mm
(H*) 6265.0 mm	(Q) 2166.0 mm

## Options

Steel tracks	Long dipperstick
Third auxiliary hydraulic line (Clamshell Piping)	



hire@pjpk.com  
www.pjpk.com



Doosan Benelux S.A./N.V.  
Drève Richelle167  
1410 Waterloo  
Tel.: +32 2 371 68 11 Fax: +32 2 371 69 00



**Bobcat**®

www.bobcat.eu